



Wood Duck Nest Box Design & Assembly Directions

Instructions, Illustrations & Photos Courtesy of MWDI
and Scott Jason, Harford County Chapter, Ducks Unlimited

Side door opening design for easy mounting & monitoring access light-weight, field-proven effectiveness

Design can be easily converted to a top lid opening by keeping the door panel in one piece and permanently attaching to sides; add hinge to roof instead of attaching.

Design can also be converted to an "east-west" side door by cutting the door panel into "thirds", by attaching the upper and lower portions and then by adding a hinged piece in the middle as desired height.

Materials Needed for One Box

10-foot, 10" wide board

(ideally cypress or cedar for longevity)

High quality wood, #2 grade, rough cut one side

Nominal 10" width and 1" thickness

12" boards can easily be used, adhere to the same length dimensions.

Other lumber is also feasible but other hardwoods will add significant weight.

Softwoods require treatment and will not last as long.

Premium wood glue.

Apply liberally to all seams, splits and knot areas. Will insure boxes hold up much longer than those without glue.

Tools Needed

- Tape measure, marking pencil
- Cross cut saw
- Jig saw (for oval opening)
- Drill
- Small bit for hinge screw holes and door latch holes
- Slightly larger bit to ream door latch entry hole
- Wood or metal bit approx $\frac{3}{8}$ " - $\frac{1}{2}$ " diameter for bottom weep holes
- Shears for cutting hardware cloth (rat wire) or scissors for plastic gutter guard
- Staple gun & 1/2" staples (Arrow T50 type) to install ladder
- Hammer (to tap ladder staples in deeper) Air powered staple gun to attach wood pieces (or hammer for nail use - drill with bit for screws)

One – 12-14" x 3-4" exit ladder

Hardware cloth (rat wire), small mesh, curved in center to form slight hump, easier ladder use by ducklings.

Trim or fold edges to prevent injury to ducklings from sharp wire points.

Plastic gutter guard will also work well.

Cut with scissors.

1 1/2" stainless steel or galvanized staples, 1/4" narrow crown, 18 gauge

for use in compressed air staple gun.

1 1/2" stainless steel, ribbed, cedar shake nails may also be used with hammer or 1 1/2" screws.

Screws

2 – 2" deck type for hinge

1 – 2 1/3" deck type for latch screw

1 – 1 " deck type for door pull out handle (optional)

Approximate Length Dimensions

(Not much left over wood from 10 foot board)

Can adjust dimensions as desired.

- Front, Side, Back & Door – 23 1/2" each
- Roof @ 14" +/-
- Floor @ 7 3/4"



Step by Step Procedures

1. Make Marking Jig out of separate wood pieces (optional)

Need 2 wood pieces - 1" nominal thickness.

One piece approx 6" by approx 9 1/4".

Second piece can be smaller width, same length.

Place over first piece and screw to make a 1 1/4" overlap along the edge.

Will be used later. Instructions follow.



2. Make box support jig to help hold side panels when nailing (optional)

- Take a 2"x 4" scrap and nail a nominal 10" wood piece to its side so it will stand up. Use this piece opposite of the side panel to be nailed to help support it as indicated in Steps 7 & 8.



3. Cut 10 foot board into dimension pieces.

Label the front, back, side & door when cut

- Front, Side, Back & Door – 23 1/2" (approximate, can be slightly shorter or longer as desired)
- Roof @ 14"
- Floor @ 7 3/4"

Make sure rough cut sides face the box interior when box is assembled.





Step by Step Procedures continued

3. Cut Board into pieces continued

- Cut the door panel into two pieces on a 45 degree angle starting the cut at 9" from the bottom of the 23 1/2" door panel
- Make sure the rough side of the door panel is face down when making this cut. This will insure that the door panel will overlap the lower piece like a shingle when installed and the rough side will be facing the box interior

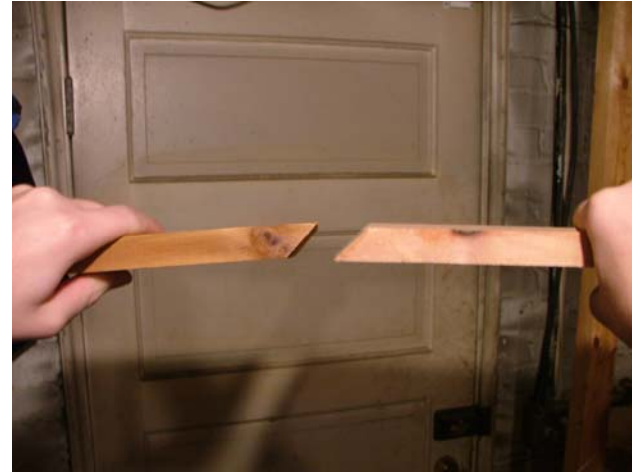

Roof Pitch !!

Note: Pitch is achieved when mounting the box by slightly tilting it forward and then screwing (or bolting) it to maintain that position angle. Pitch allows for rain runoff as well as a little gravity assistance for the ducklings exiting the nest!



4. Draw a 3" high by 4" wide oval opening 2 1/2" down from the top of the front board.

- Cut the opening with a jig saw after drilling a starter hole for the jig saw blade.

Notes: (1) Some jig saw blades can start the hole avoiding the need for drilled starter hole. (2) Some people use 4" circle holes which are OK, but this will provide less protection against raccoons being able to grab the hen as they can get their shoulders & arms in deeper.





Step by Step Procedures continued

5. Cut 12-14" x 3-4" plastic or wire ladder & bend to form a slight bow

Staple to the inside front board just below the bottom lip of the oval opening.
Tap the staples in with hammer.



Make sure the rat wire edge points have been trimmed or folded inward to avoid duckling injury.



6. Affix ladder to the inside of Front panel near the opening.

- Use the T-50 type staples and tap in with hammer.
Make sure pointed edges are trimmed or folded inward.



7. Optional: Glue and assemble FLOOR & lower Door Nest RETAINER boards into one piece.

- Make sure lower door retainer piece is set on the OUTSIDE edge of the floor board.
Set aside until Step 10.

The floor can be inserted separately and the lower door panel then attached after the floor is in place.

It may necessary to use wood shims to pry the other panels open to accept the floor if they have warped slightly.





Step by Step Procedures continued

8. Use MARKING JIG.

- Draw a nail guide line along one smooth side edge of the front and back panels. (Rough cut side will be placed inward).
- Draw a nail guide line along the bottom of the smooth side edge of the front, back and side panels.



9. Assemble Three sides (Front panel, Back panel and non-door Side panel)

- Lay the unmarked Side panel in between the front panel (on right) and the Back panel (on left). Rough sides facing up.
- Lift the center piece (Side panel) and liberally glue the right edge now facing upright.
- Lift the Front panel and place it (i.e. the marked guide line edge) on top of the outside edge of glued Side panel.
- Position the Support Jig on the opposite side.
- Nail along the guide line, spacing nails every few inches as desired.
- Rotate the attached 2 panels until the Front panel faces down.
- Glue the upright edge of the Side panel.
- Place the Support Jig opposite it.
- Place the Back panel on top of the glued edge and nail along the guide line

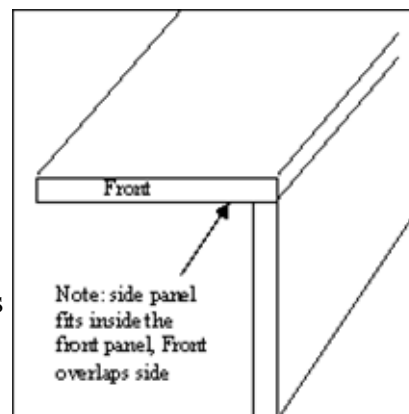



Step by Step Procedures continued

9. Assemble Three sides continued

You will now have a three-sided structure looking like this.

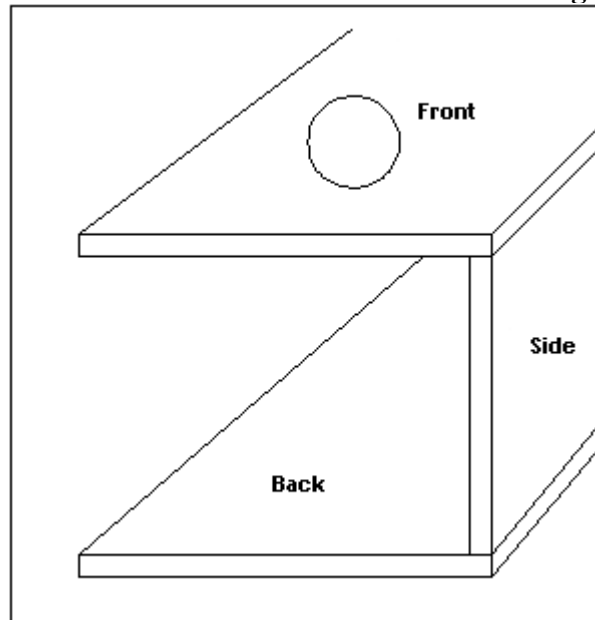

10. Floor Assembly

- Rotate the 3 sided box so the opening faces up.
- Apply glue to the bottom of the panel facing you where the floor will be inserted.
- Apply glue to the two outside edges of the floor piece.
- Insert it into the 3 sided box from Step 9. If necessary, pry the sides slightly outward to accommodate the floor.
- Nail the floor on all three sides following the marking jig guide lines.

Note: picture shows floor inserted, glued and nailed.

Lower door panel is about to be placed on outside edge and nailed.





Step by Step Procedures continued

11. Roof Assembly

First insert the door and shim if necessary to insure it will fit when installed after the roof is in place.

- While fitting the door into the 3 sided box, use shims at the top of the door where it attaches to the front and back sides if necessary.

The shims will hold the roof supports in position while it is affixed and assure the door will swing freely once the roof is installed.

If the door fits easily into the 3-sided box, shims for the Roof are unnecessary but they will help hold the door in fixed position when hinge holes are drilled. (Step 12).

Some doors may need to be slightly trimmed on the side before shimming into place if the other panels are slightly warped. Trimming a very small amount off the top of the door will also insure it does not bind when opened or slide the door panel down slightly where it overlaps the lower door panel and 45 degree cut.

- With the door & shims in place, apply glue and position the Roof.

Overlap the back very slightly (1/4" or so) to help keep water out of the wood cross cut.

The Roof should overlap the Front primarily.

- Nail into place on 3 sides.
Do not nail the door shut! (It happens enough to mention it!)



Step by Step Procedures continued

12. Door Assembly (and Latch)

- Mark a line where the side hinge holes need to be drilled on each side approximately 3” from the top.

The location is not critical (avoid knots for example), but it’s very important that each hole is exactly the same distance from the top on each side.

- Drill the hinge holes with a bit equal to or slightly smaller than the screw size.

Do not drill too deeply into the door panel. Make sure the hole is straight and perpendicular to the side.

- Insert and screw in one screw into the door and only partially tighten. Do not screw the head flush with the side.
- Insert the second screw and repeat.
- Once both screws are almost fully in place, examine the door gap on each side of the opening.
- Tighten the screw on one side or the other to balance the gap so the door will swing most freely.
- Slightly tighten both screws when the door is centered. It is not necessary to screw it in too tightly, especially if your hinge screws are greater than 2”.





Step by Step Procedures continued

12. Door Latch continued

- Drill 45 degree hole thru the front panel into the door for the door latch screw.
- Then, open the door and use a larger bit and ream the hole drilled into the side panel so that the latch screw will move easily back and forth through the reamed hole.
- Close the door and insert a 2" or longer screw, only finger tighten to close so that a tool is not needed to re-open in the field.
- **Note** : Picture actually shows the latch screw set low on the door panel. This is done when the entire door panel is made to pull open....our initial design. We have modified it to provide a higher nest retainer piece to hide the hen better and make her feel more comfortable if present when the boxes are checked so we can avoid unnecessarily flushing her.



Picture shows the door panel open with a 1" screw in the center to be used to pull the door towards you when checking the nest. Besides approaching it quietly, reverse the latch screw to free the door (finger tight to begin with!) and then pull the door slowly. The hen should remain if only partially opened and approached in this manner.

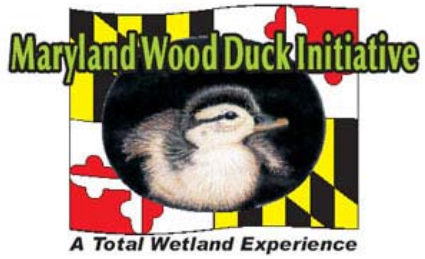

Step by Step Procedures continued

13. Drill weep holes

- Use 3/8" – 1/2" wood bit.
- Turn the finished box upside down.
- Drill holes in the floor to allow rain to escape

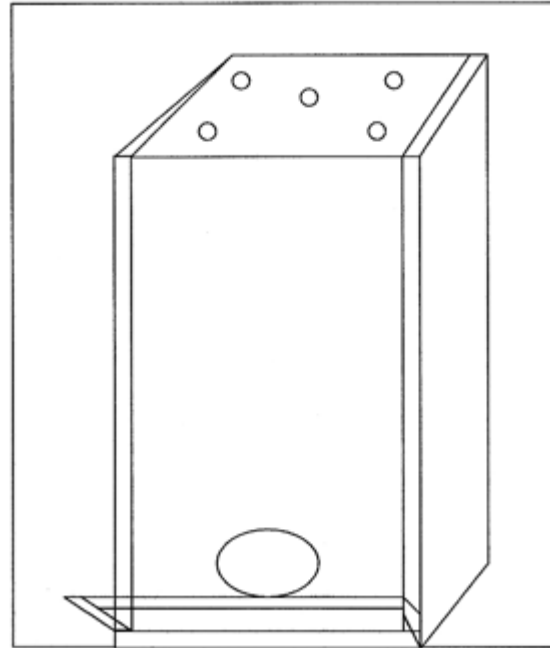



Step by Step Procedures continued

14. Quality Control

- Inspect the box & check for any splits.
- Glue any splits and knot areas you find as the wood will shrink.

Note: this box has 4" circle hole as example versus the oval shaped hole in the background.



The Finished Box

Add wood chips and you're ready to go.

15. Mounting

The side door facilitates mounting to wood or metal poles. No mounting boards are needed.

To 4x4 poles, MWDI recommends 2-3 screws be used to attach it firmly. 2" hex head, pole barn screws w/ neowashers are ideal. Hex head screws do not strip like many deck type screws and they have a washer to help hold the wood surface. Removal of boxes is facilitated without potential damage to the top threads.

If necessary, drill starter holes into the wood pole to make sure the screws penetrate easily so there is no box wobble after being installed.

Open the side panel and start the screws. The first two can be angled slightly upwards to allow easy drill access. The third screw can be angled downward. Flip the drill over so it will easily fit and function inside the box above the retainer piece while screwing.

Offset the screws slightly so that the **box tilts somewhat forward**. This will allow rain to drain off the Roof and provide a slight gravity assist to ducklings exiting the box.

Remember to get the guard at least 3 feet above water and 4 feet on firm ground !!! Close all gaps as well.



On metal poles, 2 bolts with an interior washer will hold the box firmly. The holes can be drilled into the same side panel as screws or, if desired, into the back panel.